

MAFR302 series

AIR UNIT (F.R.UNIT)



Option: **MP41**

Symbol

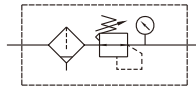

Specification

Model	MAFR302		
Bore No.	8A	10A	15A
Port size	1/4	3/8	1/2
Medium	Air		
Operating perssure range (*)	0.05~1 MPa		
Proof pressure	1.5 MPa		
Regulated pressure range	0.05~0.85 MPa		
Ambient temperature	- 5~+60°C (No freezing)		
Filter element	Standard: 5μm, Option: 40μm		
Drain capacity	35 cm ³		
Attachment	Pressure gauge (PG-20), L type bracket		
Weight	490 g		

* Standard unit contains semi-auto-drain function when operating pressure below 0.05 MPa.

* Choose auto-drain FMRF300, the pressure range is 0.15~1 MPa.

Order example

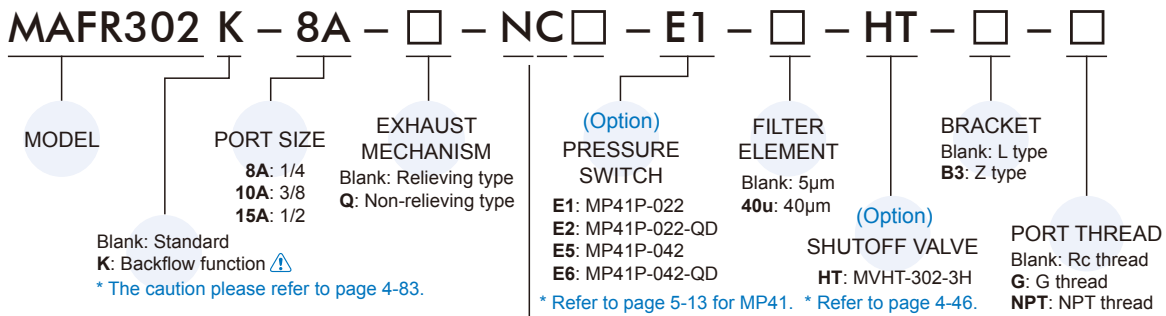

(Option) ACCESSORIES

Bowl	Pressure gauge	Drain valve
Blank: PC bowl M: Metal bowl N: Nylon bowl	Blank: Pressure gauge (PG-20) C: External pressure gauge (PG-40) + Gauge adapter set (A-MAR302) A: Gauge adapter set (A-MAR302)	Blank: Semi-auto drain D: Auto drain valve (FMRF300)

* Standard type regulator can not release the outlet pressure completely, even if inlet pressure was cut off, and the backflow function (K) must be applied to completely remove the residual pressure.

* The (Q) non-relieving type regulator is used. When the output pressure is higher than the set pressure, the output pressure will not flow out through the exhaust hole.

* PG-40 (C), A-MAR302 (A) and MP41 (E*) can not be selected at the same time.

* Be sure to use above check valves when redirecting the air flow on the inlet side of the lubricator.

Flow feature

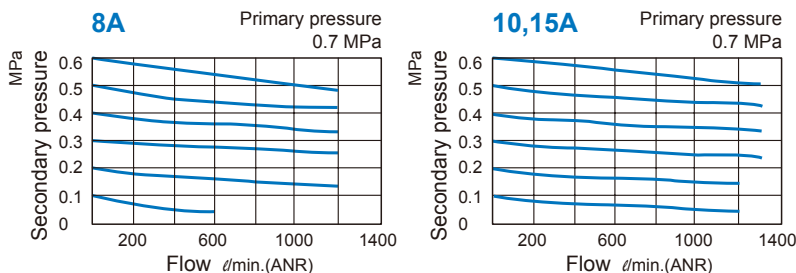

⚠ Caution

Metal bowl

Before assembling or disassembling, push the lock plate down to the end, and confirm that is detached from the body then rotate the bowl, otherwise the lock plate will be deformed or the body will be scratched.

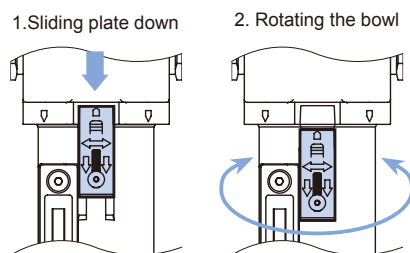

MAFR302 Dimensions

AIR UNIT (F.R.UNIT)



Panel mounting hole

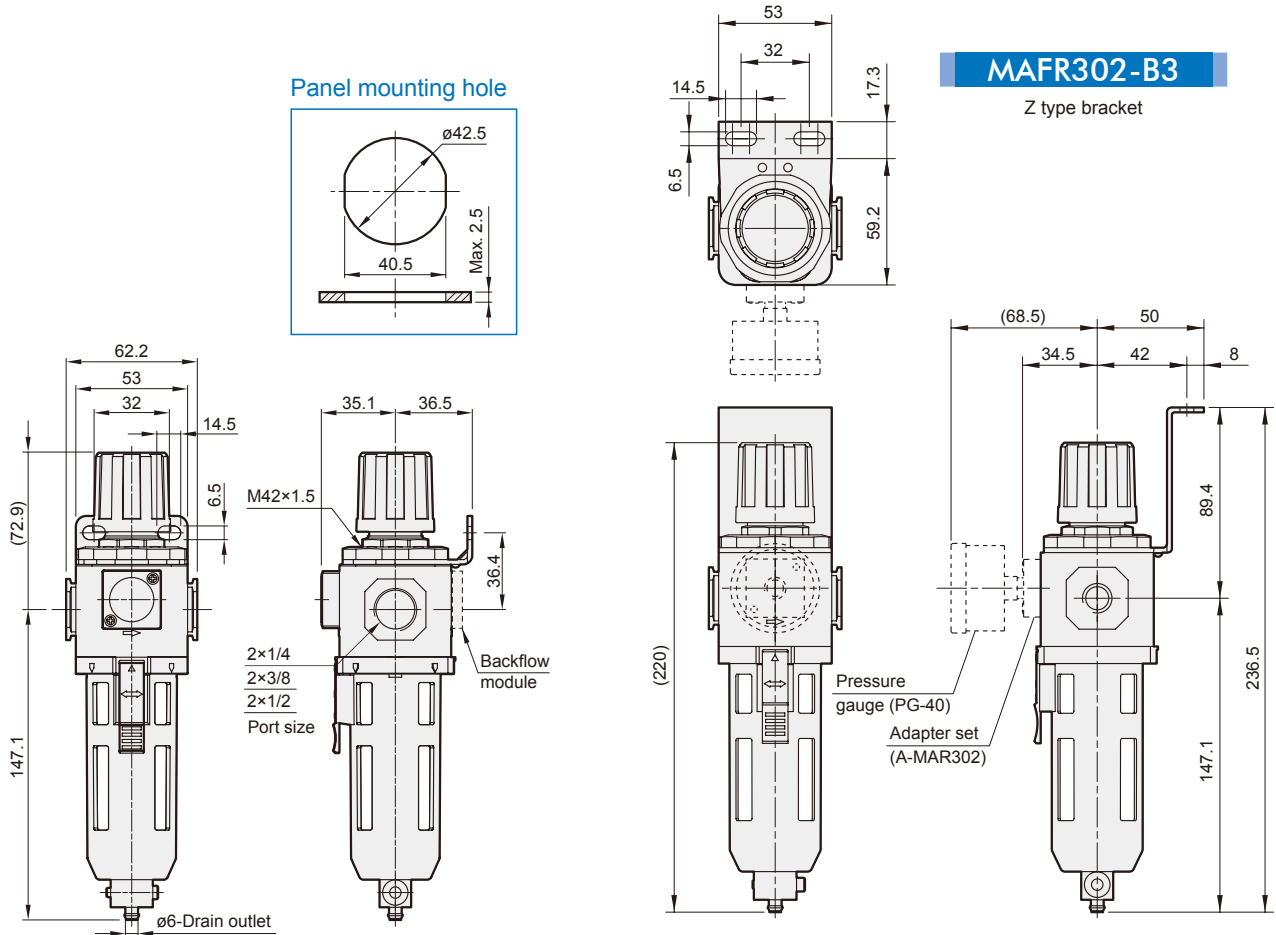
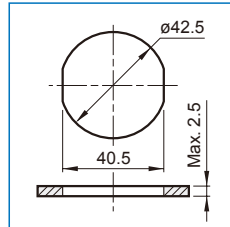

MAFR302-B3

Z type bracket

MAFR302-D

Auto drain valve

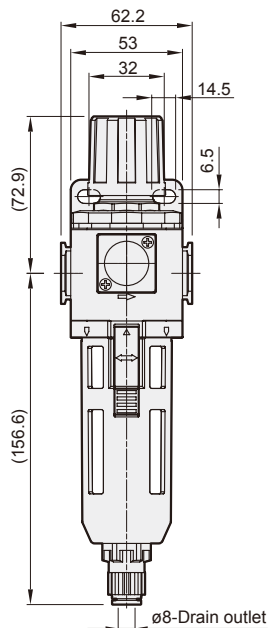

MAFR302-M

Metal bowl

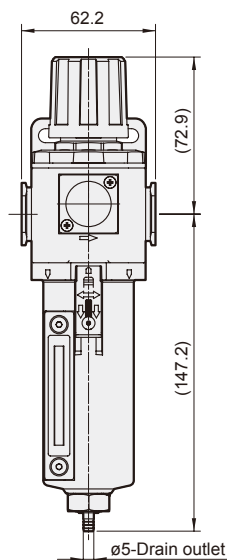

MAFR302-MD

Metal bowl + Auto drain valve

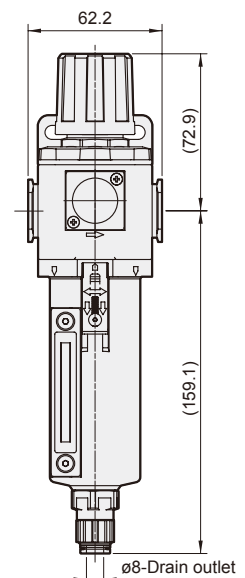

MAFR302-HT with shutoff valve

AIR UNIT (F.R.UNIT)



Mindman

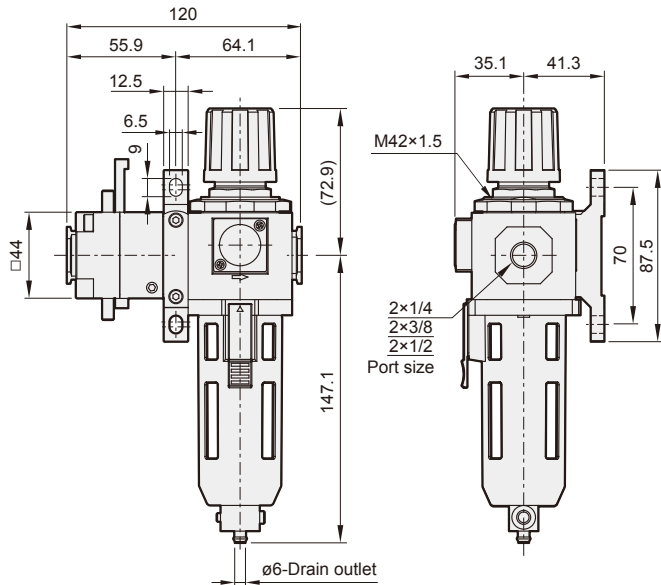

Accessories

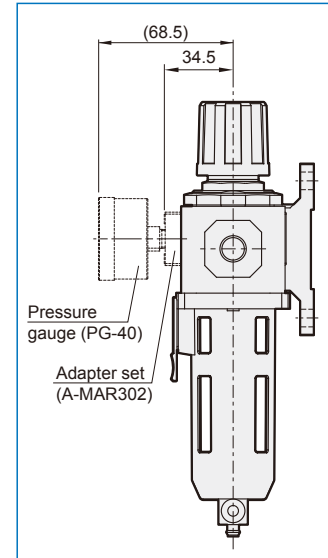

MAFR302-D-HT

Auto drain valve

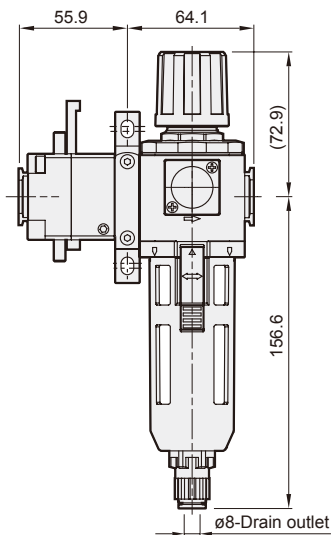

MAFR302-M-HT

Metal bowl

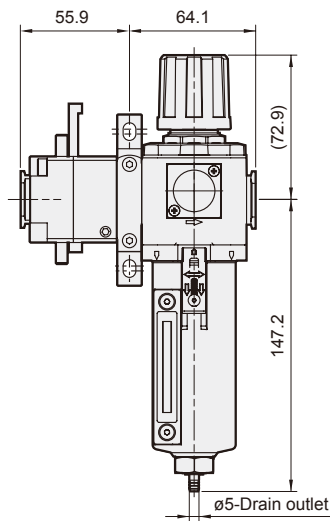

MAFR302-MD-HT

Metal bowl + Auto drain valve

