

Specification

Model	MSB*				
Tube I.D. (mm)	20	32	40	50	63,80
Port size	M5×0.8	Rc1/8		Rc1/4	
Medium	Air				
Operating pressure range	0.2~1 MPa				
Proof pressure	1.5 MPa				
Ambient temperature	-5~+60°C (No freezing)				
Lubrication	Not required				
Cushion	With rubber cushion pad				
Sensor switch (*)	RCB, RCE, RCE1, RDEP, RCA for ø50				
Sensor switch holder	HS (for RCA)				

* RCA, RCB, RCE, RCE1, RDEP specifications, please refer to page 8-8, 10, 12, 13, 18.

Order example

MSBD – 32 – 20 – (L – K – L) – G – V – 4E2 – AC110

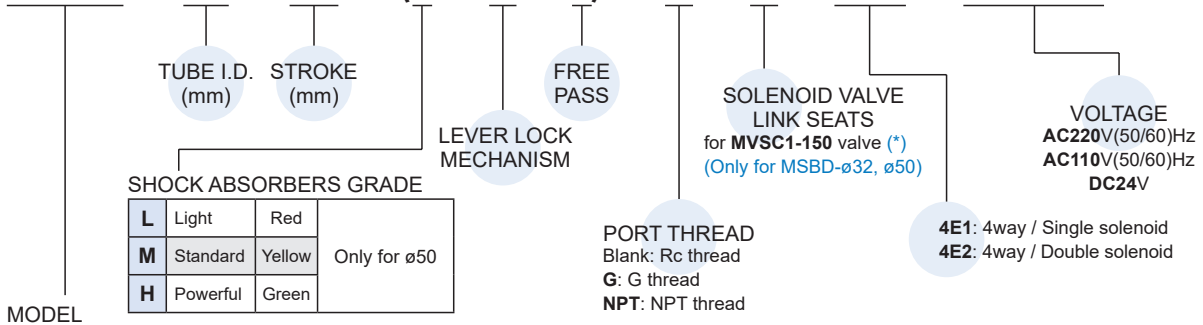



MODEL	Type of cylinder	Operation type	Standard stroke	Magnet	Sensor switch	Weight
MSBD		Shockless stopper (Double acting with spring)	ø32-20	○	RCE, RCE1, RDEP	740 g
			ø50-30	○	RCA	1800 g
			ø63-30	○	RCB, RCE, RCE1, RDEP	3680 g
			ø80-40	○	RCA	6820 g

* MVSC1-150 specification, please refer to page 1-22 (Vol.1).

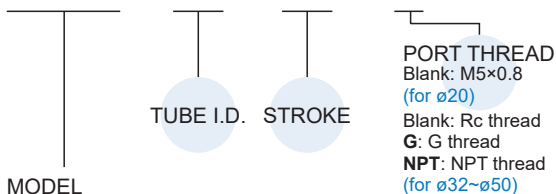
MSBR – 40 – 30 – G

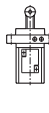

MODEL	Type of cylinder	Operation type	Standard stroke	Magnet	Sensor switch	Weight
MSBR		Stopper with roller (Double acting)	ø20-20	○	RCB	250 g
		Stopper with roller (Single acting-Spring extended)	ø32-20	○	RCE, RCE1, RDEP	740 g
			ø40-30	×	—	1400 g
			ø50-30	×	—	1800 g
MSBS		Direct stopper (Double acting)	ø20-10	○	RCB	192 g
			ø32-20	○	RCE, RCE1, RDEP	720 g
			ø50-30	○	RCA	1850 g

Piping diagram

Single acting

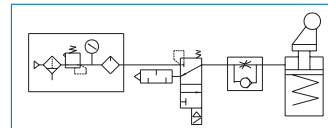

Double acting

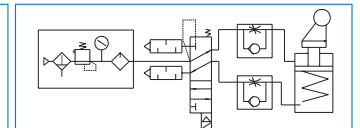

Pallet control stopper type

Shock absorber built-in

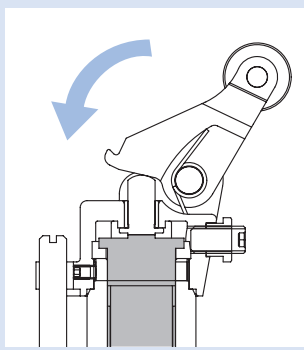

Absorbs the shock when the carried object stops, and stops the object softly on the right Position. There is an adapter between the lever and shock absorber, which straightens the inclined load on the lever and transmits it to the lever.

Lever lock mechanism

With this optional feature, the carried object is not pushed back by the lever. Also the Object returns to the right position after being lifted up. The lock is released by supplying air and lowering the rod.

Stopper mechanism

Guide bar equipped for fixing the direction of the roller lever.

Light aluminum

Main cylinder part, shock absorber, and roller lever are integrated in the aluminum die cast body. The best cylinder for the light and space-saving conveyor line.

Free pass mechanism

Setting the pass-plate on the lever holder, the lever is fixed in the OFF position. Use the optional feature when the carried object needs to pass over the cylinder.

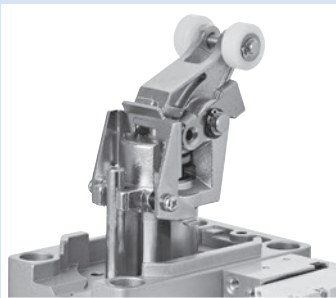

Solenoid valve and sensor switch

Magnet-sensing sensor switch is available for MS** Reed or "solid state" switches with LED is fixed, not need to adjust the position, 5/2 solenoid Valve can be directly mounted on the cylinder.

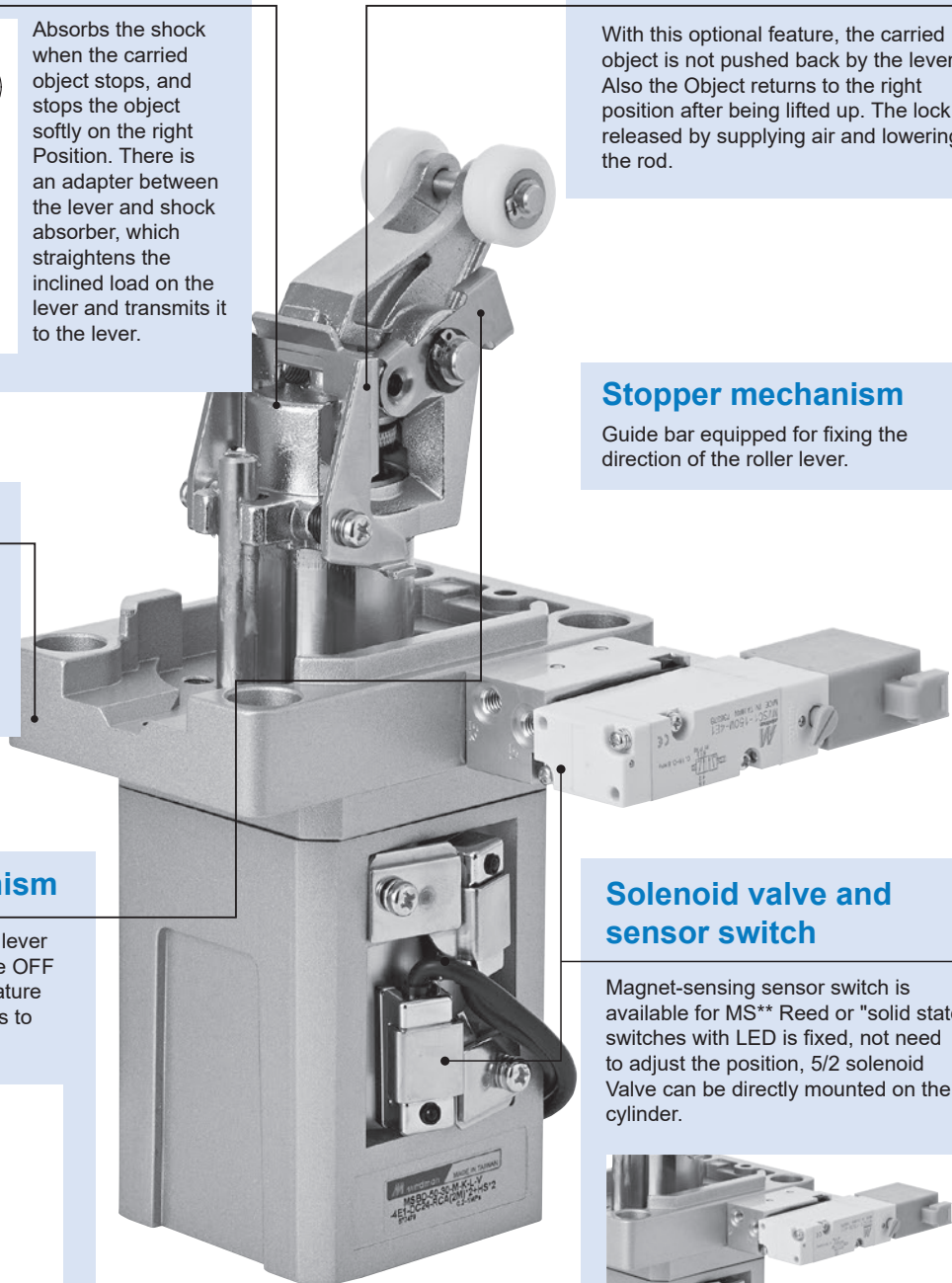
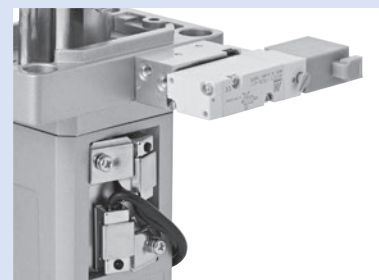

MSBD $\phi 32-20$

Capacity

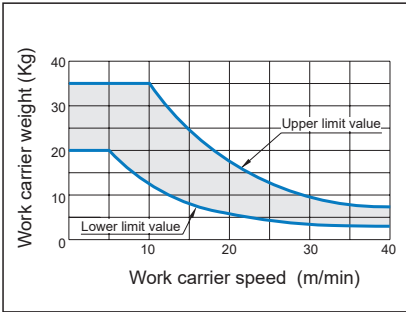

MSBD $\phi 32-20, \phi 50-30$

Normal lateral load

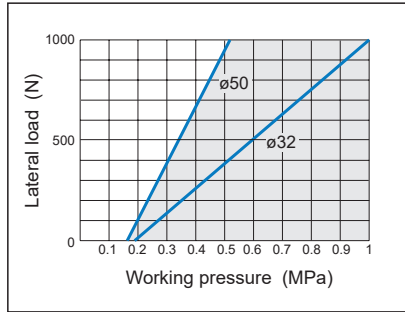

MSBD $\phi 50-30$

Capacity Light weight type

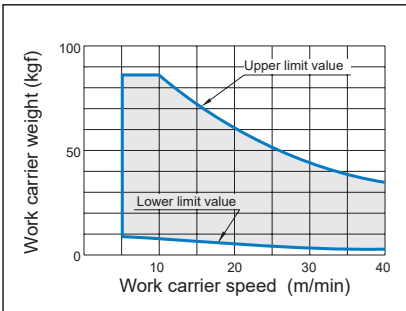

Capacity Standard type

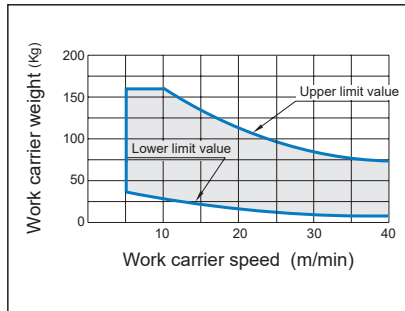

Capacity Heavy duty type

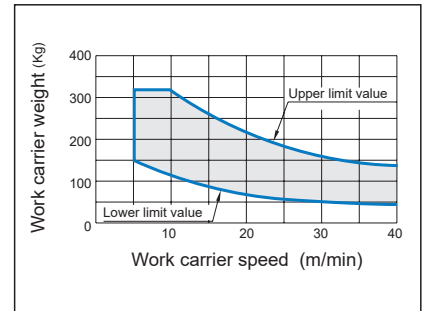

MSBD $\phi 63-30, \phi 80-40$

Capacity

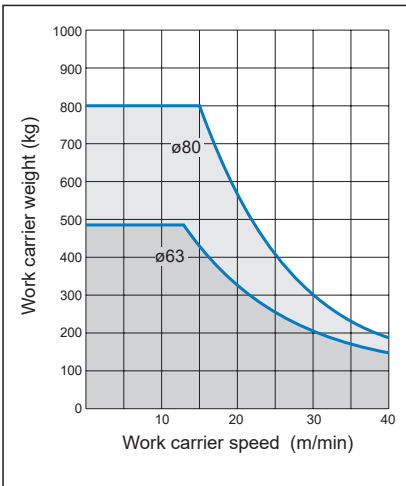

Normal lateral load

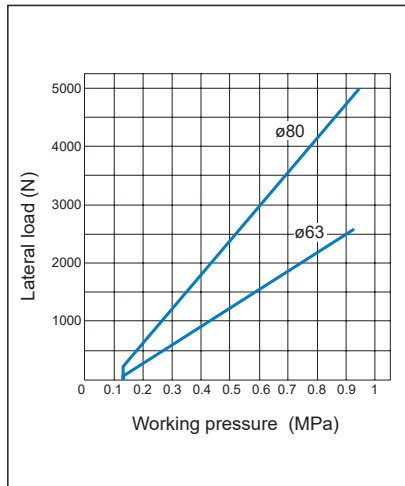

MSBD $\phi 32-20$

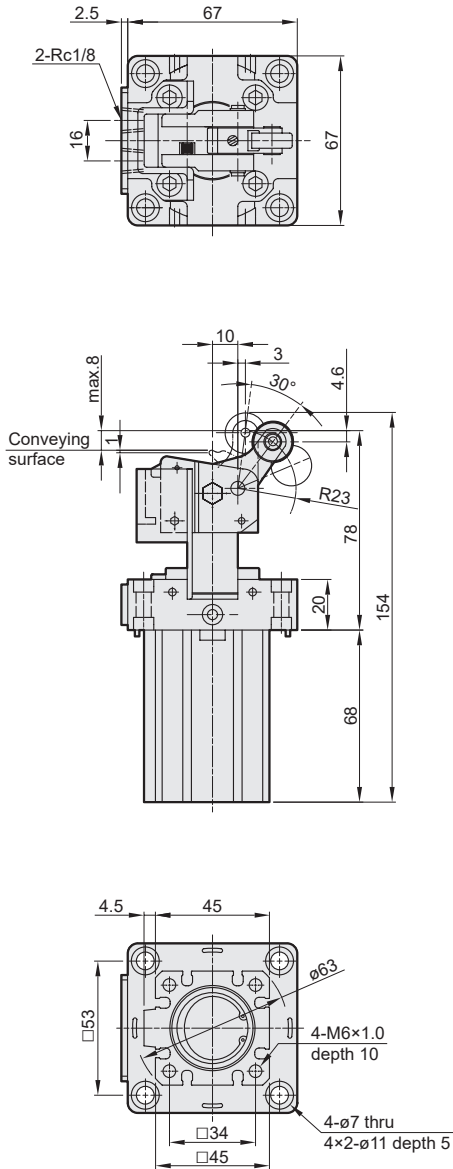

MSBD $\phi 32-20-V$

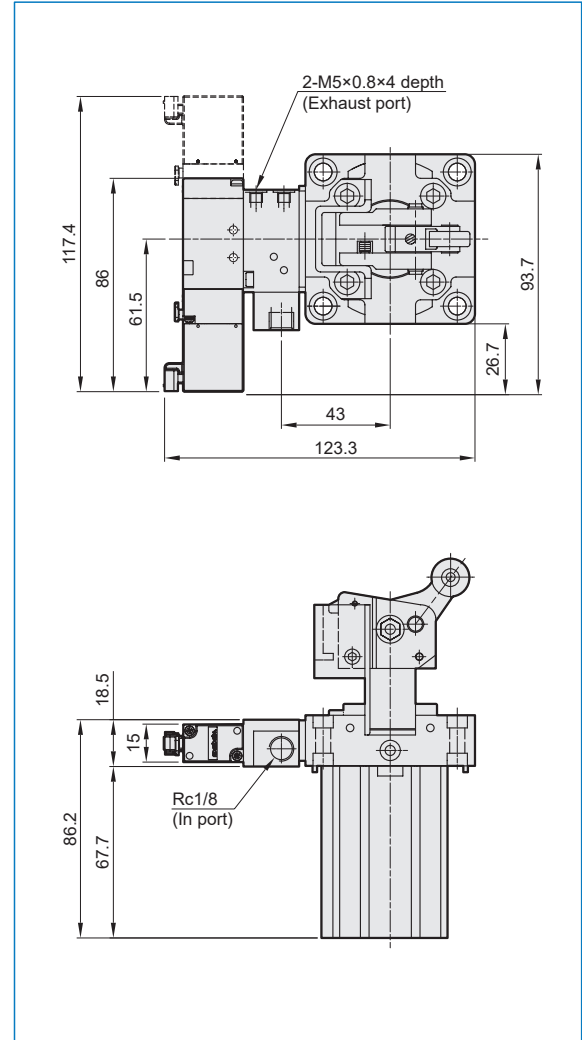

MSBD $\phi 50-30$

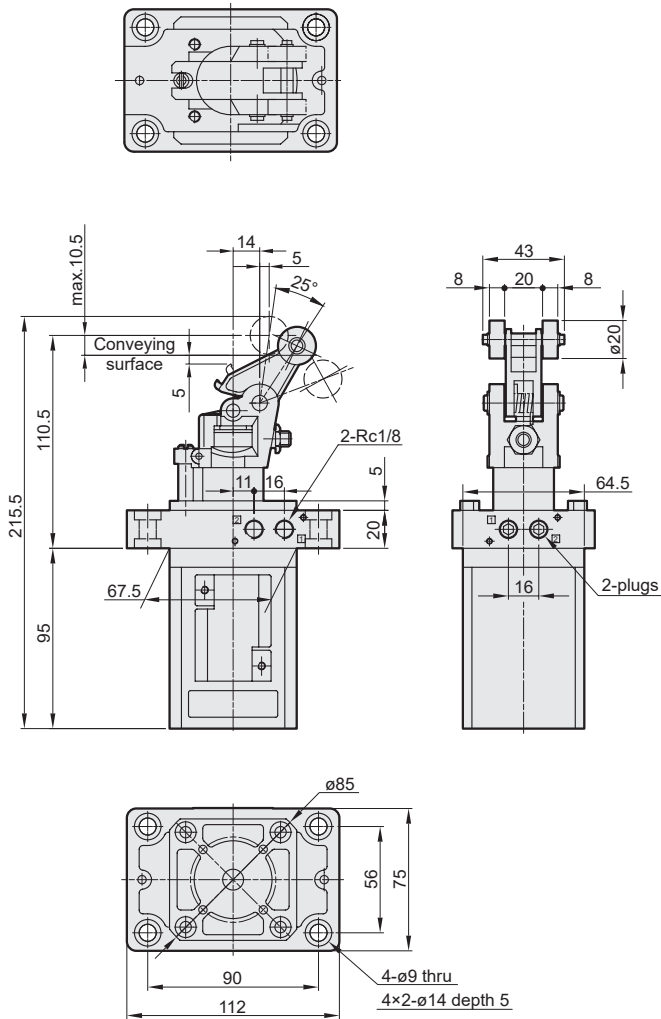

MSBD $\phi 50-30-V$

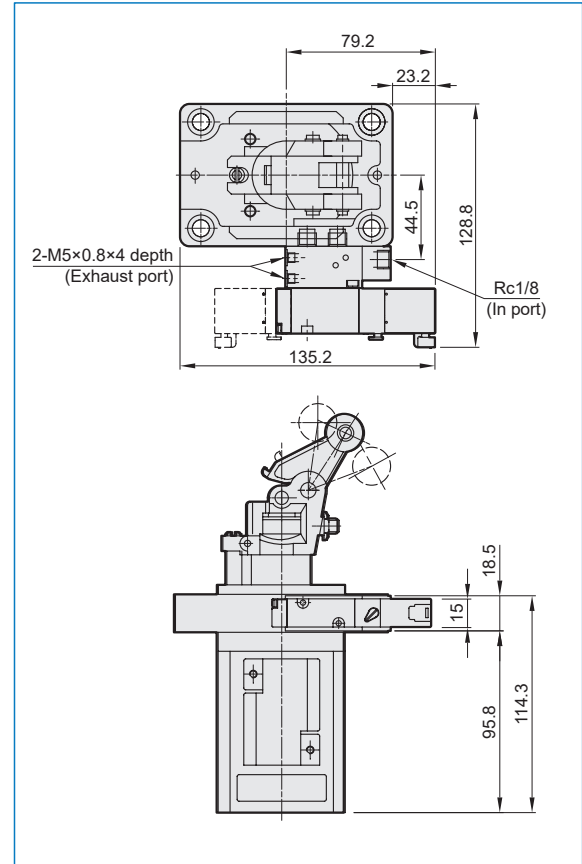

Option accessories

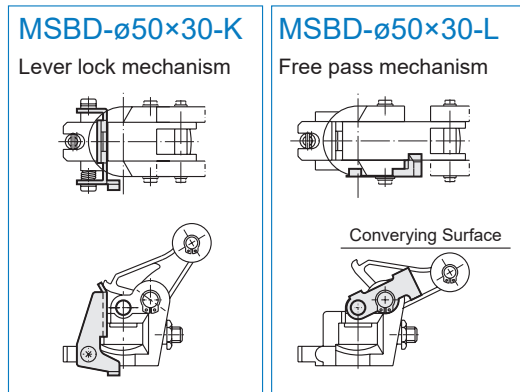

STOPPER CYLINDER

MSBD $\varnothing 63-30$
MSBD $\varnothing 80-40$

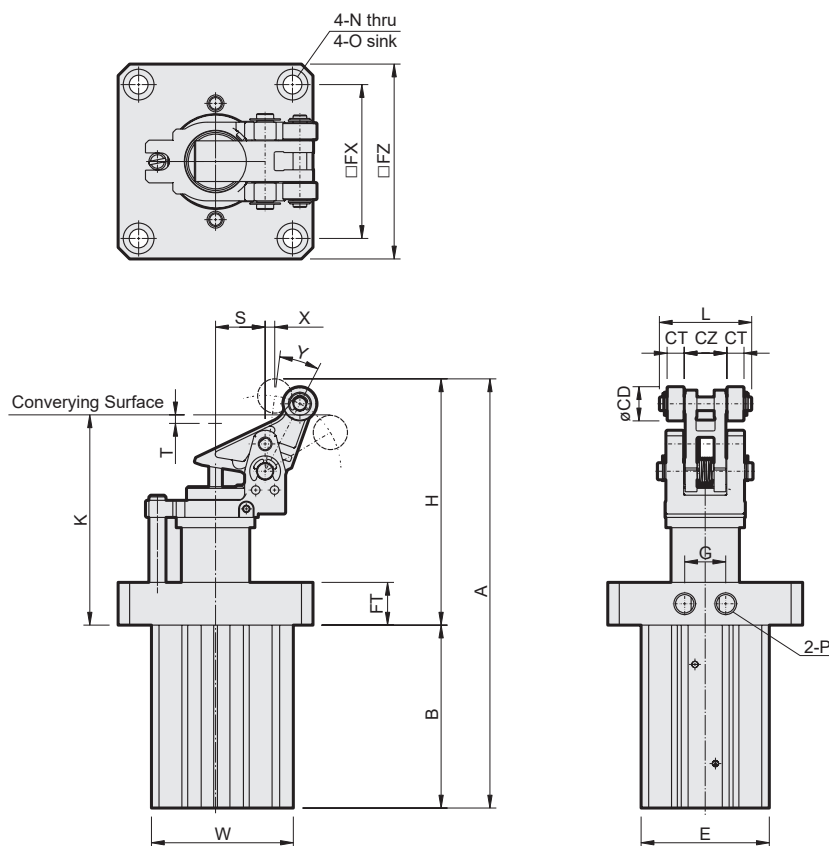

Option accessories

MSBD- $\varnothing 63-30-K$
MSBD- $\varnothing 80-40-K$

Lever lock mechanism

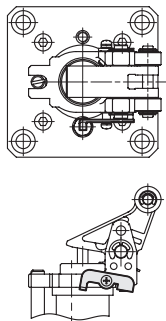

MSBD- $\varnothing 63-30-L$
MSBD- $\varnothing 80-40-L$

Free pass mechanism

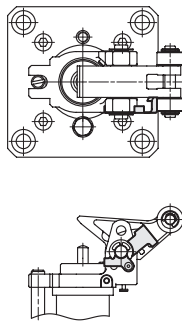

Tube I.D.	Stroke	A	B	CD	CT	CZ	E	FT	FX	FZ	G	H	K	L	N	O	P	S	T	W	X	Y
63	30	251	107	20	10	25	75	25	90	114	24	144	123	54	$\varnothing 11$	$\varnothing 18 \times 6$ depth	Rc1/4	29	5	83	6	20°
80	40	322.5	145	25	12	30	94	25	110	140	24	177.5	150	63	$\varnothing 13$	$\varnothing 20 \times 6$ depth	Rc1/4	36	4	102	8	22°

MSBR

Capacity

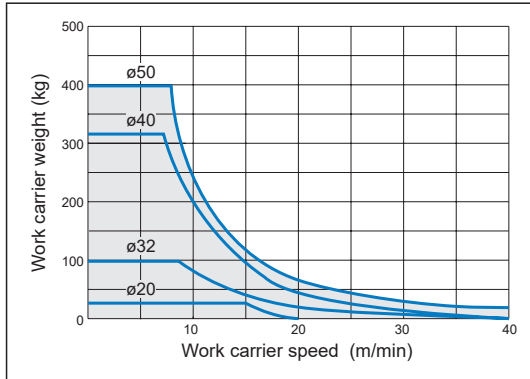

MSBR

Normal lateral load

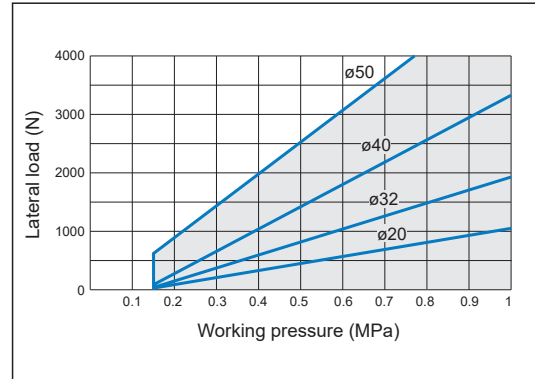

MSBS

Capacity

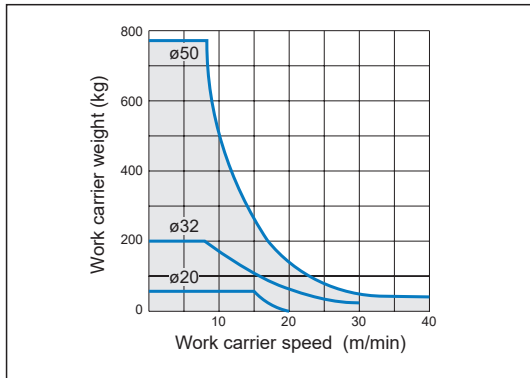

MSBS

Normal lateral load

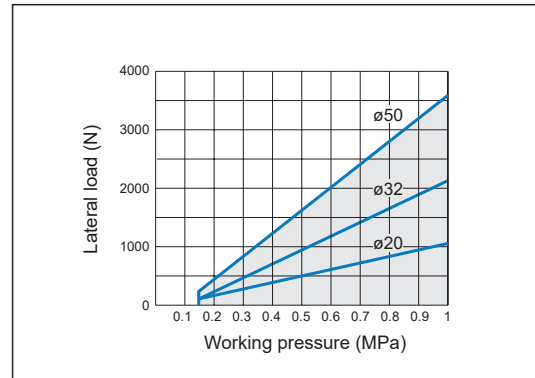

STOPPER CYLINDER

MSBR $\phi 20-20$

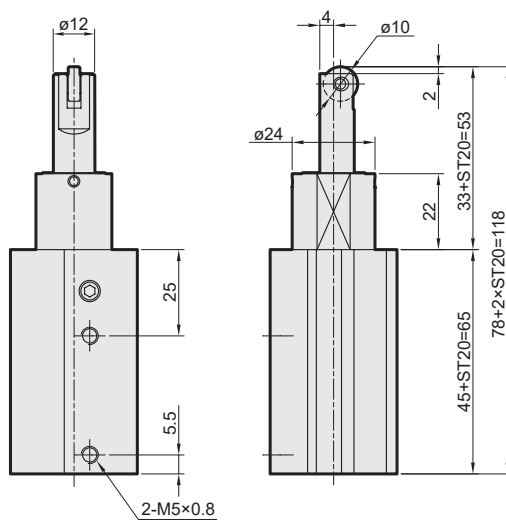
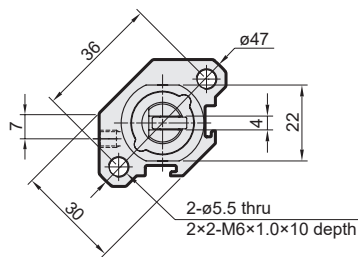

MSBR $\phi 32-20$

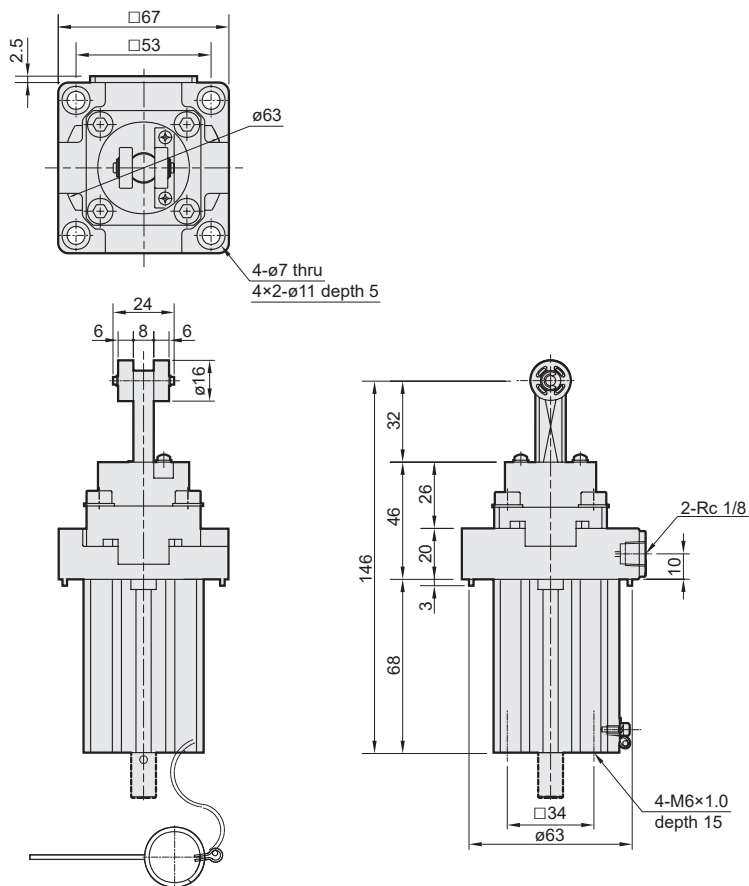

STOPPER CYLINDER

MSBR $\varnothing 40-30$

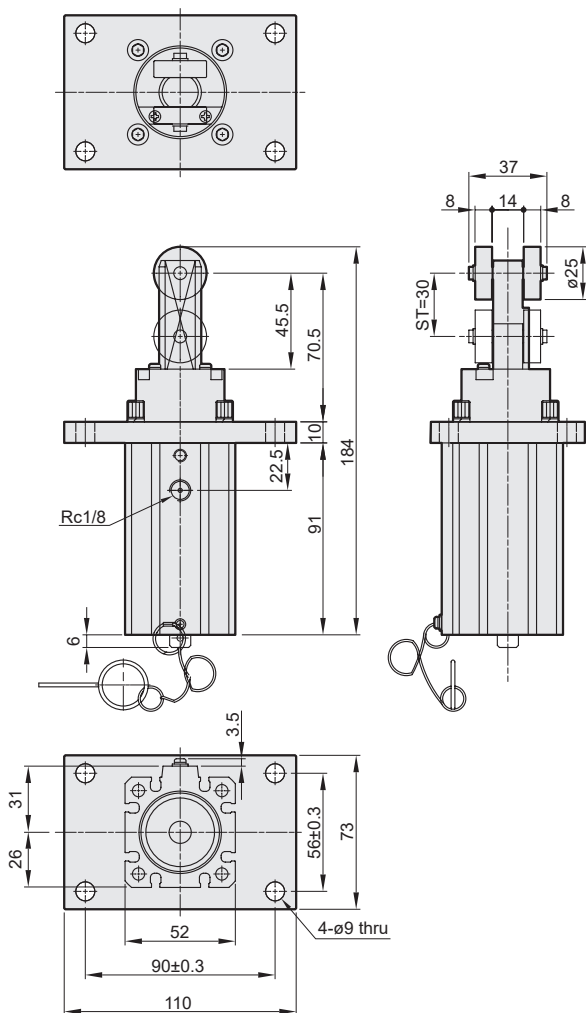

MSBR $\varnothing 50-30$

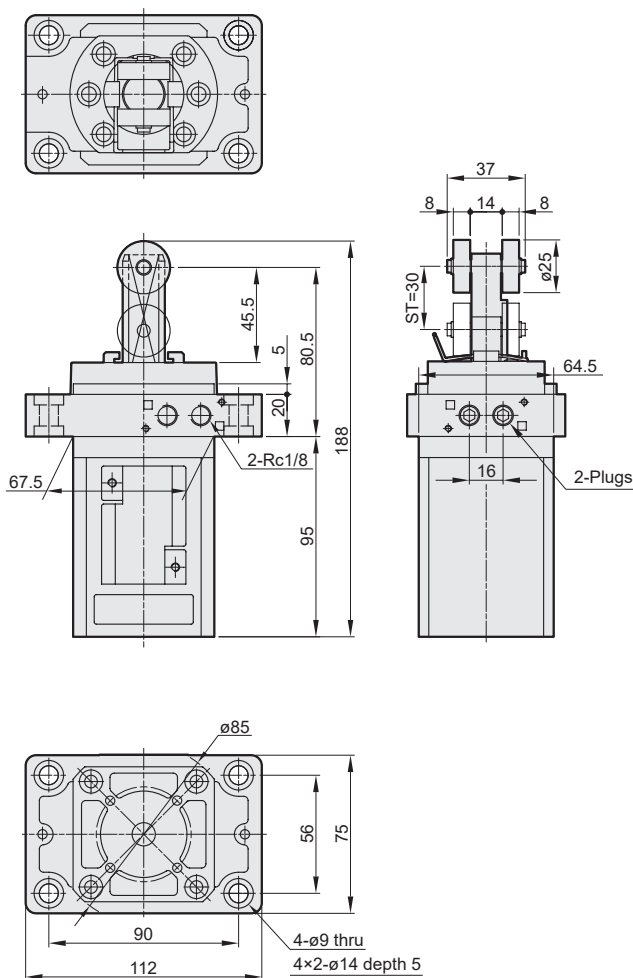

MSBS $\phi 20-10$

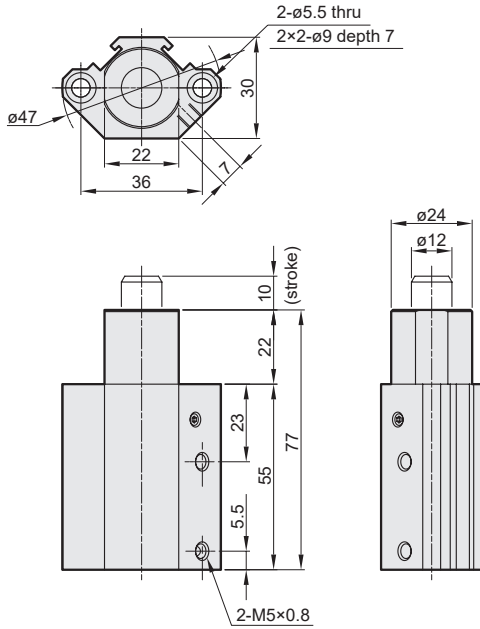

MSBS $\phi 32-20$

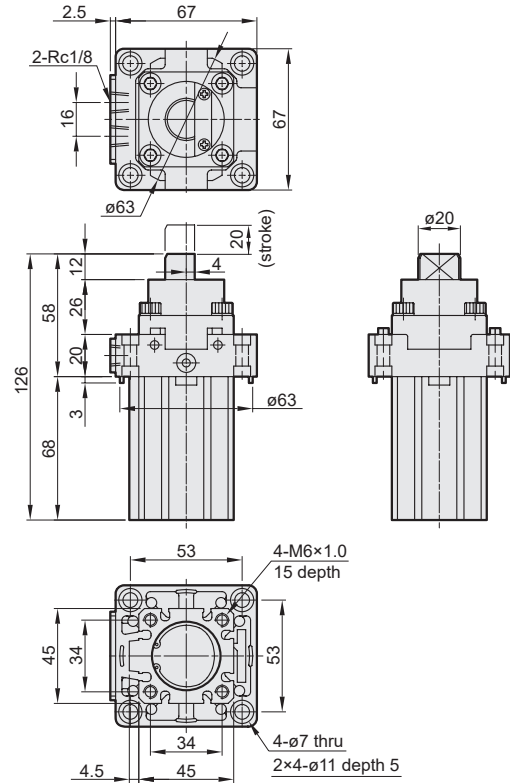

MSBS $\phi 50-30$

